

# RCD32-E11T

## Features

- > Type B for charging piles and compatible with A+6 type on-board residual current protection module
- > All-in-One highly integrated digital residual current action indicator
- > Rated primary current-carrying capacity (single-phase/three-phase) 32 A

## Standard

- > Meets GB/T 40820 (IEC 62955) mode triple charging RDC-PD phase Requirements for the operation of residual current
- > Meet the basic residual current operating characteristics of GB/T 22794 (IEC 62423).requirements, and adapt to the DC 6mA test requirements



Product Appearance

### Trip-Current (residual current related characteristics)

Wav.	Freq.	Min.	Typ.	Max.	Unit
AC	50Hz	21.0	23.0	24.0	mA
A0	50Hz	4.5	24.0	42.0	mA
A90	50Hz	6.3	24.0	42.0	mA
A135	50Hz	3.3	27.0	42.0	mA
2PDC	50Hz	3.5	5.2	7.0	mA
3PDC	50Hz	3.1	4.6	6.2	mA
S-DC	-	3.0	4.7	6.0	mA
F	-	15.0	35.0	42.0	mA

### Trip-Time (residual current related characteristics)

Wav.	Freq.	Current	Typ.	Unit
AC	50Hz	30mA	115.0	ms
AC	50Hz	60mA	60.0	ms
AC	50Hz	150mA	20.0	ms
AC	50Hz	500mA	15.0	ms
A0	50Hz	42mA	50.0	ms
A0	50Hz	84mA	25.0	ms
A0	50Hz	350mA	20.0	ms
A0	50Hz	42mA+6mADC	45.0	ms
A0	50Hz	84mA+6mADC	30.0	ms
A0	50Hz	210mA+6mADC	25.0	ms
2PDC/3PDC	50Hz	60mA	40.0	ms
2PDC/3PDC	50Hz	120mA	25.0	ms
2PDC/3PDC	50Hz	300mA	15.0	ms
S-DC	-	6mA	140.0	ms
S-DC	-	60mA	40.0	ms
S-DC	-	300mA	12.0	ms
F	-	210mA	15.0	ms

### Electrical & Reliability Characteristics

Char.	Value
Working Temperature	-40°C~105°C
Storage Temperature	-40°C~105°C
Working humidity	≤95%
Supply Voltage (VDD) <sup>(1)</sup>	4.85~5.15 VDC
Consumption	≤110 mW
Electrical Clearance, Primary-Primary	≥ 6.28 mm
Electrical Clearance, Primary-Secondary	≥ 6.6 mm
Creepage Distance, Primary-Primary	≥ 6.7 mm
Creepage Distance, Primary-Secondary	≥ 7.0 mm
Voltage Input, low level	0~0.6VDC
Voltage Input, high level	4.2~5VDC
FIT <sup>(2)</sup>	Contact us
Designed Life <sup>(3)</sup>	≥ 20 years
Working Altitude <sup>(4)</sup>	≤ 4000m

<sup>(1)</sup> It is suggested to control VDD within 4.9~5.1 VDC to get better performance

<sup>(2)</sup> The calculation of FIT according to IEC 61709, is based on the FIT values of different different components in the BoM list. And the calculation principle: ground mobile, no dust or harmful substances

<sup>(3)</sup> The calculation and claim of product life is based on the MTBF value according to IEC 61709

<sup>(4)</sup> The calculation about altitude is based on the principles: reinforced insulation, insulation material group I, pollution degree II, overvoltage category II

# RCD32-E11T

## Typical Application Schematic & Pin Definition

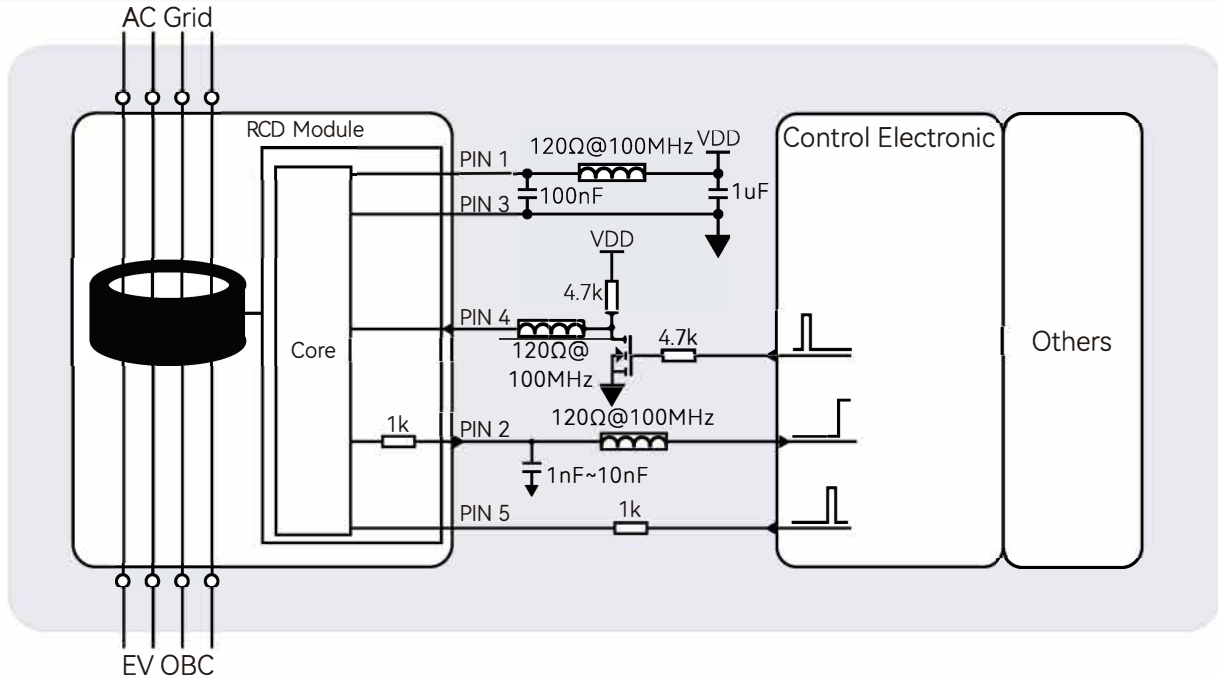

Pin-No.	Pin Name	Function
PIN-1	VDD	<ul style="list-style-type: none"> <li>&gt; Product power supply pin, standard power supply voltage 5 VDC</li> <li>&gt; The input voltage range is required to be 4.85-5.15 VDC, and the power output capacity should be &gt;100mA</li> <li>&gt; Power ripple <math>\leq 150\text{mV}</math> ( It is recommended to use an LDO circuit, with particular attention to the load response performance of the LDO chip. Refer to the power management chip LP2985A-50DB )</li> <li>&gt; Suggest adding magnetic beads and filtering capacitors on the power supply end, and placing them near the pins</li> </ul>
PIN-2	TRIP	<ul style="list-style-type: none"> <li>&gt; Product action signal output pin</li> <li>&gt; When residual current in the circuit is detected to exceed the threshold, the output level changes from low to high</li> <li>&gt; Suggest adding magnetic beads and filtering capacitors on the power supply end, and placing them near the pins</li> </ul>
PIN-3	GND	<ul style="list-style-type: none"> <li>&gt; Product power grounding pin</li> </ul>
PIN-4	CAL (Calibration)	<ul style="list-style-type: none"> <li>&gt; Product calibration command input pins</li> <li>&gt; When the pin is pulled down to a low level for 50-100ms and then restored to a high level, the product enters calibration mode</li> <li>&gt; When using this pin function, it is generally necessary to ensure that the charging circuit is disconnected during the self check process of the charging station to prevent residual current in the circuit from affecting the zero calibration effect during the zero calibration process</li> <li>&gt; When using this pin, be sure to design according to the recommended timing logic</li> <li>&gt; Suggest adding magnetic beads to the PIN pin and placing them close to the pin</li> </ul>
PIN-5	TEST (Self Test)	<ul style="list-style-type: none"> <li>&gt; Product self inspection input pins</li> <li>&gt; Before turning on charging, a simulation test is performed on the product by pulling the pin up to VDD to verify whether the product functions properly</li> </ul>
PIN-6~PIN-9	AC Primary	> Main circuit connection should be made while simultaneously connecting the AC input or AC output
PIN-10~PIN-13	AC Primary	> Main circuit connection should be made while simultaneously connecting the AC input or AC output



# RCD32-E11T

## Digital Signal Flip Threshold

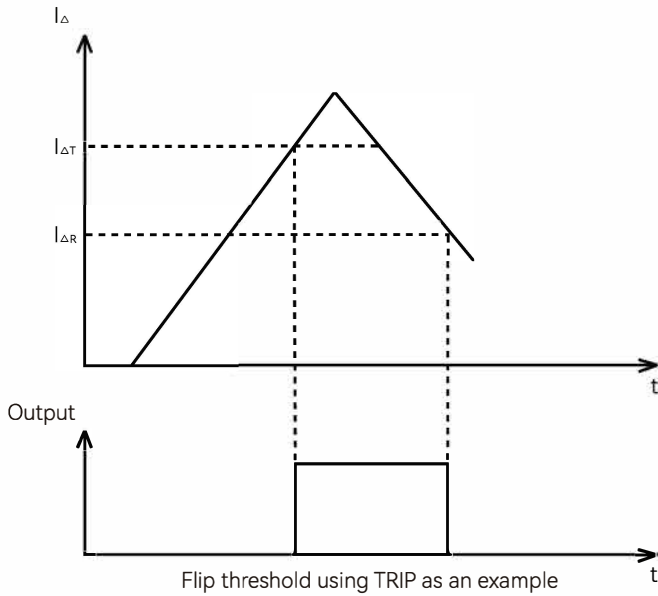

- > For avoiding the signal oscillation, tripping signal output flipping has been set with tripping threshold and recovery threshold
- > When tripping threshold  $I_{\Delta T}$  reached, the related X-OUT flip, and when the current decrease to the recovery threshold  $I_{\Delta R}$ , the related X-OUT flip again, back to low level state
- >  $I_{\Delta T}$  is set as 100% typical tripping value, and  $I_{\Delta R}$  is set as 55% typical tripping value

## Version history

Version number	Modifications	Reason for modification
V1.0.0	Official First Release Version	
V1.1.0	Update Product Dimension Drawings	Erratum
V1.1.1	Update Product Feature Parameters	Erratum
V1.1.2	Update Electrical & Reliability Parameters	Add
V1.1.3	Product Specification Review	Review
V1.1.4	Add Recommended Packaging Drawings	Add
V1.2.0	Upgrade Product Specification UI	
V1.3.1	Update Electrical & Reliability Parameters	Erratum

## Self-Test Circuit

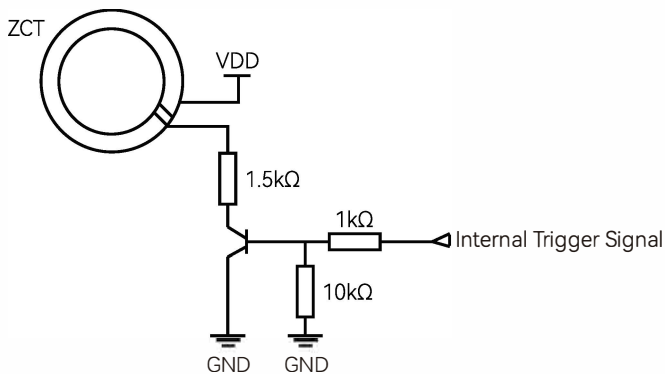

- > 2 winding on the ZCT to generate simulated DC residual current
- > By using VDD to generate typical value = 6.53 mADC simulated residual current
- > Use the most stringent 6mADC value to detect whether the module can work properly and identify residual current